



Boldly Creative



Expert Customer Service



Focus On Quality



Ships Same Day

Patent(s) Pending

Sliding Rail Kit for Dell Servers

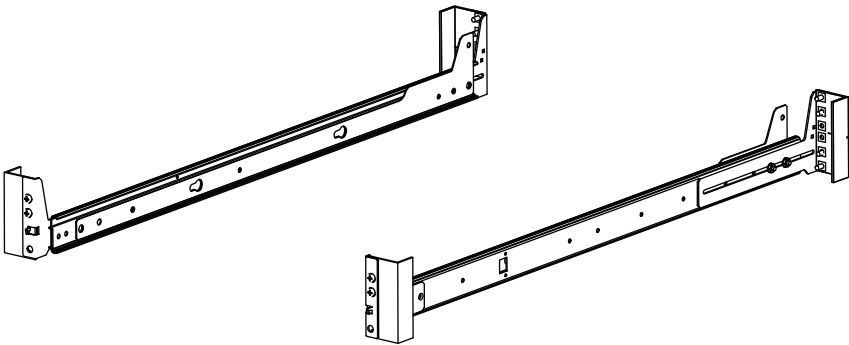

Installation Instructions

P/N: 2URAIL-R7

P/N: 2UARM-R7 (Optional)

Kit Contents

Kit Contents

- (2) Inner Rail/Shim Assemblies
- (2) Outer Rail/Rack Bracket Assemblies

Rail Hardware:

- (5) 8-32 Keps Nuts
- (5) 8-32 x .375 Truss Head Screws

Rack Hardware Kit (2 bags):

- (12) 10-32 Pan Head Screws
- (12) 12-24 Pan Head Screws
- (12) 12-24 Cage Nuts
- (12) 12-24 Square Nuts

Installation Instructions

Step 1. Attach Rear Brackets: Attach the rear brackets to the outer rail assemblies, using included 8-32 x .375 truss head screws and keps nuts. Make sure you attach them at the desired "Mounting Depth".

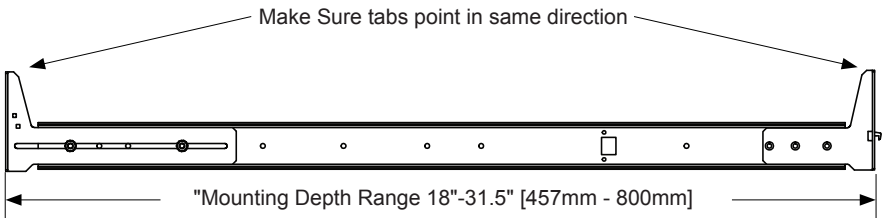

Step 2. Rail Attachment: Slide the innertrack of the rail completely out of the outer rail. You do this by pulling forward on the White Plastic Safety Latch, then out on the rail. Remove the front Dell Shoulder Nut using a 3/8" wrench, and slide the rail onto the box. Re-attach the Dell Shoulder Nut which will lock the rail in place. Repeat for the other side.

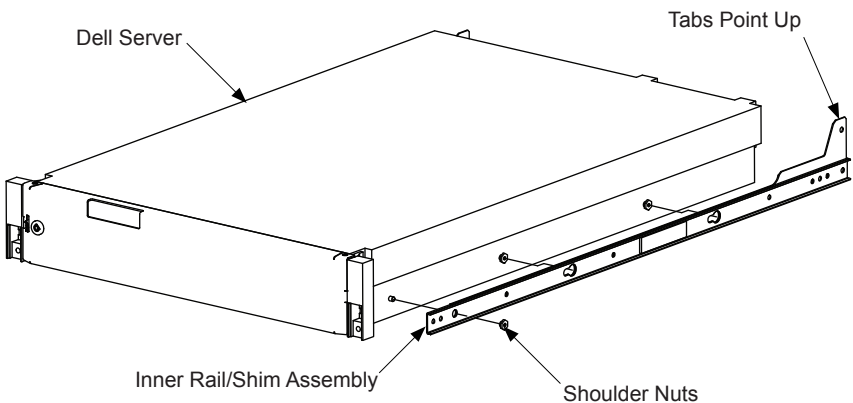

Installation Instructions

Step 3. Mount Outer Rail Assemblies: Mount both rails in the Rack as shown below.

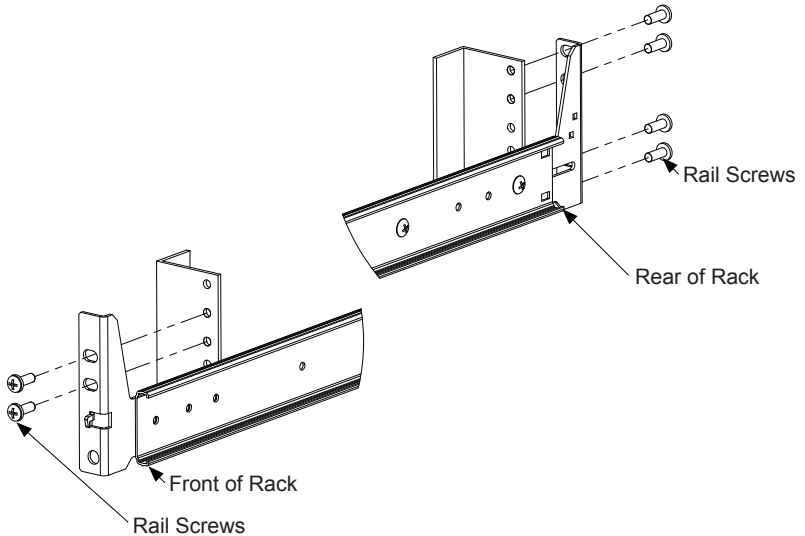

Kit Contents for Cable Management Arm

Cable Arm Hardware:

- | | |
|-----------------------------------|---------------------------------|
| (1) Cable Management Arm Assembly | (3) 8-32 Keps Nuts |
| (1) CMA Bracket Long | (1) 8-32 x .250 Pan Head Screws |
| (3) 8-32 x .375 Truss Head Screws | (2) 8-32 x .188 Pan Head Screws |

Cable Management Installation Instructions

Step 1a. For Mounting Depth Greater Than 28.3" [719mm]: Use the **Short CMA Bracket** attached to the rear of the rack (comes attached on CMA arm).

Step 1b/1c. For Mounting Depth Less Than 18"-28.3" [457mm - 719mm]: Use the **Long CMA Bracket** attached to either the Rack or the end of the Rail that is sticking out depending on your configuration.

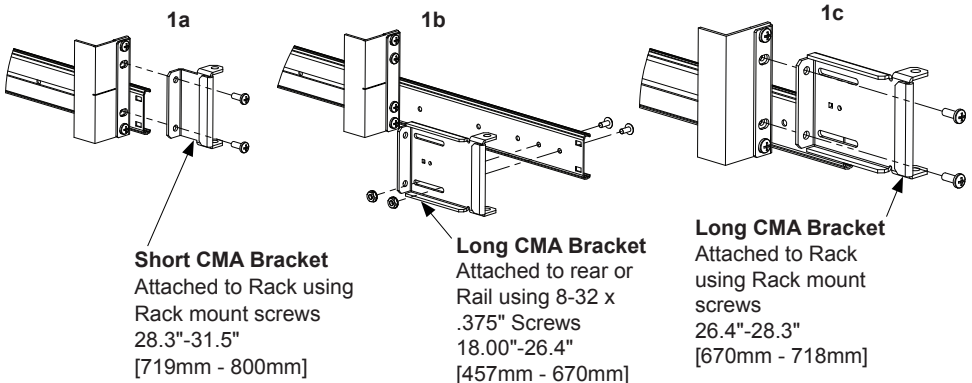

Short CMA Bracket
Attached to Rack using
Rack mount screws
28.3"-31.5"
[719mm - 800mm]

Long CMA Bracket
Attached to rear or
Rail using 8-32 x
.375" Screws
18.00"-26.4"
[457mm - 670mm]

Long CMA Bracket
Attached to Rack
using Rack mount
screws
26.4"-28.3"
[670mm - 718mm]



Cable Management Installation Instructions

Step 2. Mount Box: Using two people carefully slide the box into the rails in the rack.

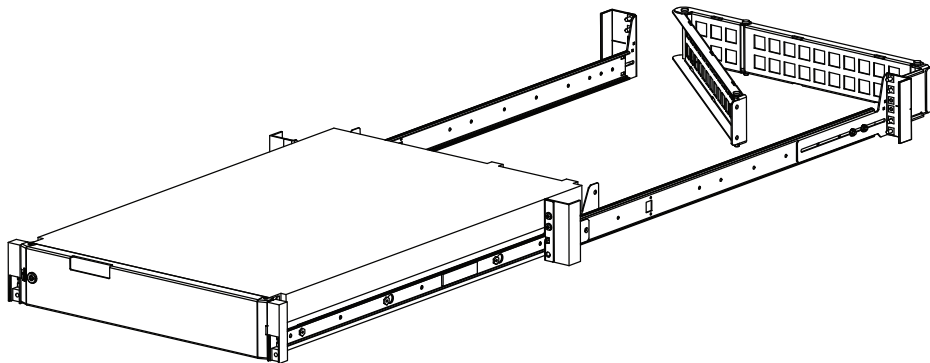

Step 3. Attach CMA: Attach the CMA Bracket to the inner shim, using the specified hardware.

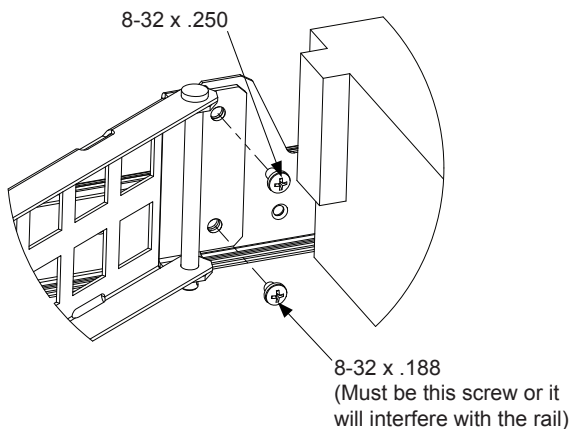

Warranty Statement

Innovation First, Inc. warrants our products against defects in material and workmanship for a period of one (1) year from the date of purchase. Innovation First, Inc. liability shall be limited to repairing or replacing, at our option, any defective product.

911 949