



Boldly Creative



Expert Customer Service



Focus On Quality



Ships Same Day

Patent(s) Pending

Generic Rackmount System

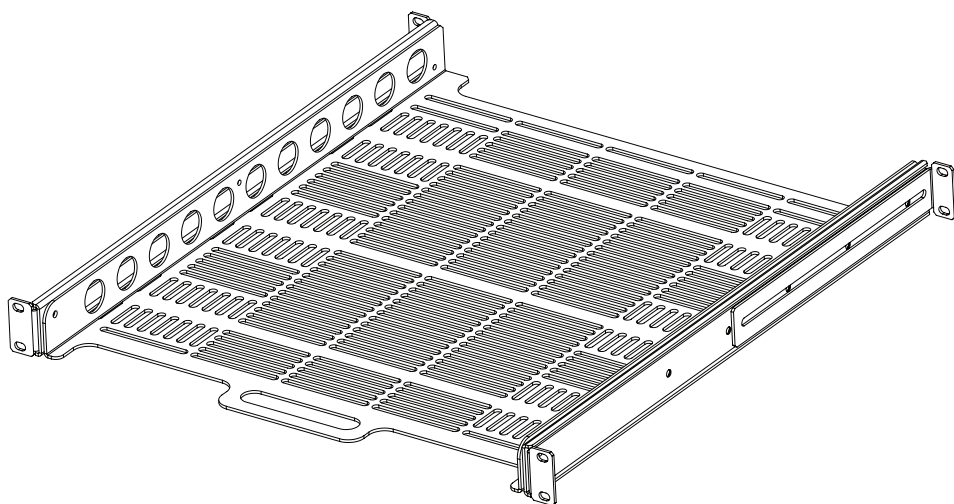

Installation Instructions

Kit P/N: 1USHL-112-20

Desktop Equipment

Tower Equipment

Laptops, Tape Drives, VCRs, etc.

Kit Contents

Mounting Hardware Kit:

- (8) 10-32 Pan Head Screws 3/8" long
- (8) 12-24 Pan Head Screws 3/8" long
- (8) 12-24 Cage Nuts
- (8) 12-24 Square Nuts

Hardware Pack Kit:

- (1) Anti-Slip Mat
- (1) Nylon Strap

(1) Partially Assembled Shelf:

Installation Instructions

Step 1. Mounting Depth: Measure the "Mounting-Depth" of your rack from the front of the "Front-Mounting-Surface" to the back of the "Back-Mounting-Surface" (see the figure below).

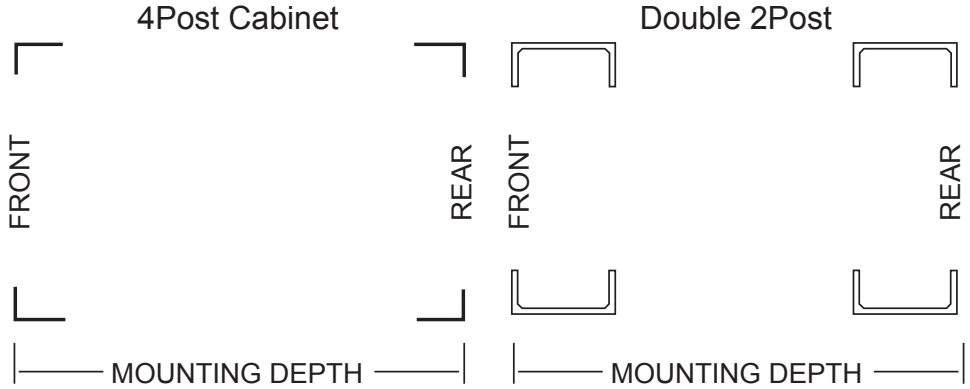

Step 2. Adjust the Shelf Depth Range (see figures below): The shelf is pre-configured to mount in racks with a Mounting-Depth of 19" to 25". The adjustable rear brackets can be reversed to allow mounting in a 3" to 18" rack. Relocate the two rear brackets as needed based on the rack's Mounting-Depth, using the existing hardware.

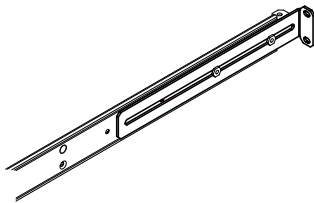

Standard Rear bracket
Range 19"-25"

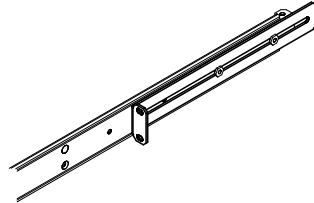

Reversed Rear Bracket
Range 3"-18"

Installation Instructions

- Step 3.** Right-Side-Up or Up-Side-Down: Equipment narrower than 16.5" should be mounted with the shelf in the Right-Side-Up orientation (see below). Equipment 16.5" to 17.5" wide must be mounted with the shelf in the Up-Side-Down orientation (see below). Right-Side-Up mounting is preferred since it saves vertical rack space.

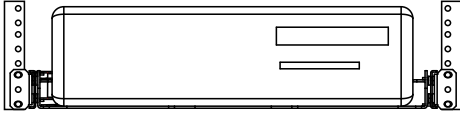

Small Desktop with the Shelf
Mounted Right-Side-Up

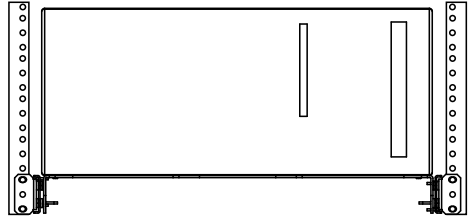

Tower with the Shelf
Mounted Up-Side-Down

- Step 4.** Shelf Location: Determine the position of the shelf in the rack. The Shelf mounts in 1U of rack space.

- Step 5.** Mount the Shelf in the Rack: Install the shelf using hardware from the Hardware Mounting Kit (included). Hardware is included for all four rack hole types: threaded 12-24 holes, threaded 10-32 holes, square holes, and round holes.

Threaded 12-24 racks use the 12-24 screws.

Threaded 10-32 racks use the 10-32 screws.

Round hole racks use the 12-24 screws and 12-24 square nuts.

Square hole racks use the black 12-24 cage nuts and 12-24 screws.

Attach the shelf using the two mounting holes at each corner (eight total). You may need to adjust the front attachment points right-to-left before tightening the holes to allow the slides to move freely.



Installation Instructions

- Step 6. Attaching the Equipment:** The attached equipment should not exceed 45 lbs. There are two options to attach the equipment to the sliding shelf. The first is to place the Anti-Slip Mat between the shelf and the equipment. The second is to use the Anti-Slip Mat, then add the Nylon Strap for additional security. There are various slots in the shelf intended for strapping the equipment. One possible strapping configuration is shown below.

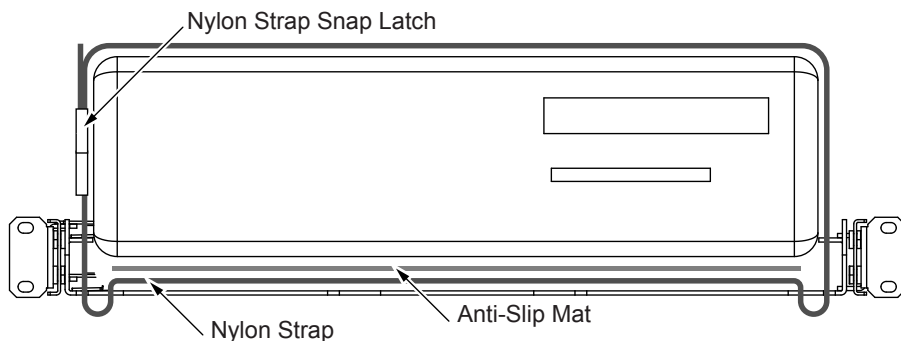

- Step 7. For “-T” Transport Option Only:** The -T option provides two straps and two anti-slip mats for added security in transportable or seismic applications. Install the thin anti-slip mat against the shelf. Install the thick anti-slip mat above the thin sheet and against the computer. Attach the computer using the straps at the front and back of the computer, looped in the manner shown in step 6.

Warranty Statement

Innovation First, Inc. warrants our products against defects in material and workmanship for a period of one (1) year from the date of purchase. Innovation First, Inc. liability shall be limited to repairing or replacing, at our option, any defective product.