



Boldly Creative



Expert Customer Service



Focus On Quality



Ships Same Day

Patent(s) Pending

1U Adapter Bracket Set

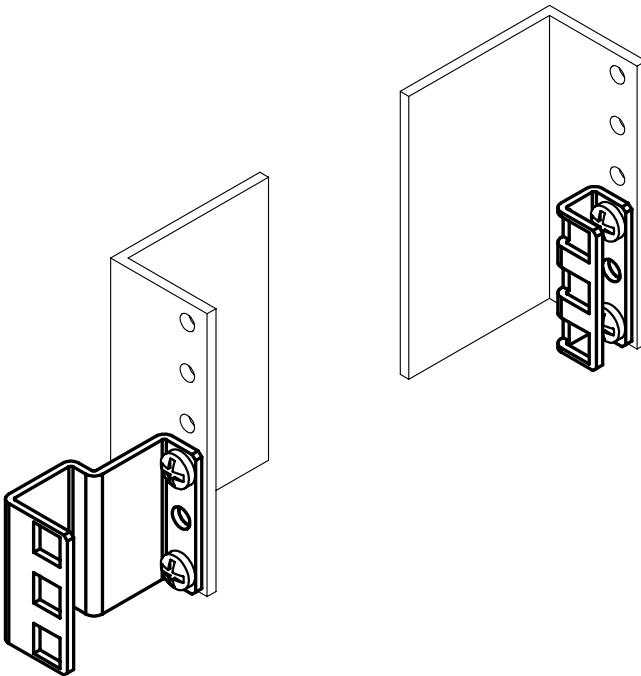

Installation Instructions

Kit P/N: 1UKIT-106

Kit Contents

Brackets:

- (2) 1U 059 – 2 Bend Bracket
- (2) 1U 100 – 2 Bend Bracket
- (2) 1U 290 – 2 Bend Bracket
- (2) 1U 200 – 4 Bend Bracket
- (2) 1U 270 – 4 Bend Bracket
- (2) 1U 350 – 4 Bend Bracket

Rack Mount Hardware Kit:

- (12) 12-24 x 3/8" Screws
- (8) 10-32 x 3/8" Screws
- (8) 12-24 Square Nuts
- (4) 12-24 Cage Nuts

Bracket Installation Instructions

Step 1. Determine your rack type: There are slight differences in the installation of this kit into a “4Post Cabinet” rack and a “Double 2Post” rack. The instructions that follow will refer to the rack type.

4Post Cabinet

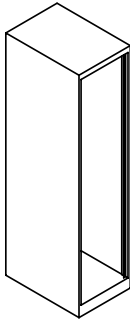

Double 2Post

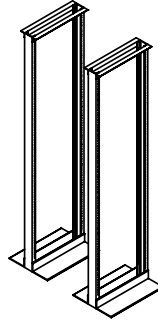

Step 2. Measure the “**Mounting-Depth**” for your rack from the front of the “Front-Mounting-Surface” to the back of the “Back-Mounting-Surface” (see the figure below).

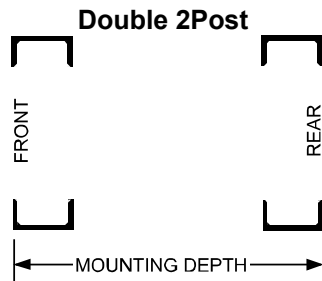
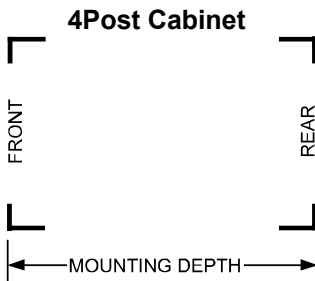

Bracket Installation Instructions (continued)

Step 3. Locate the best fit for your "Mounting-Depth" in the table below: This chart determines which adapter brackets you will need and where they should be mounted. The kit includes two each of 6 different brackets, identified as 059, 100, 290, 200, 270, and 350.

Bracket 059 = 0.59" wide with 2-bends
 Bracket 100 = 1.00" wide with 2-bends
 Bracket 290 = 2.90" wide with 2-bends
 Bracket 200 = 2.00" wide with 4-bends
 Bracket 270 = 2.70" wide with 4-bends
 Bracket 350 = 3.50" wide with 4-bends

Width code is stamped on most brackets.

4Post Rack Cabinets Only

Mounting Depth (in.)			Front-Adapter Type	Rear-Adapter Type
22 5/8	to	23 1/2	059	270+350 (ref App. B)
23 1/2	to	24 1/4	059	200+350 (ref App. B)
24 1/4	to	25 1/8	059	200+270 (ref App. B)
25 1/8	to	25 3/8	290	270+350 (ref App. B)
25 3/8	to	26 1/4	059	350
27	to	27 3/4	059	200
27 3/4	to	28 1/2	200	270
28 1/2	to	29 1/4	290	270
29 1/4	to	30	270	200

Double 2Posts Only

Rack-Depth (in.)			Front-Adapter Type	Rear-AdapterType
23 7/16	to	24 3/8	059	200+350 (ref App. B)
24 3/8	to	25 1/4	059	200+270 (ref App. B)
25 7/16	to	26 3/8	059	350
26 3/8	to	27	059	270
27	to	28	059	200
28 1/4	to	29 1/8	059 (ref Appendix A)	350
29 1/8	to	30	059 (ref Appendix A)	270

These tables summarize the typical brackets for a given Mounting Depth.

Not all combinations are shown.

Experimentation is recommended if difficulties arise.

Bracket Installation Instructions (continued)

Step 4. Adapter Location on Rail: All adapters in this kit occupy "1U" of rack space. This "1U" of space covers three holes and 1.75".

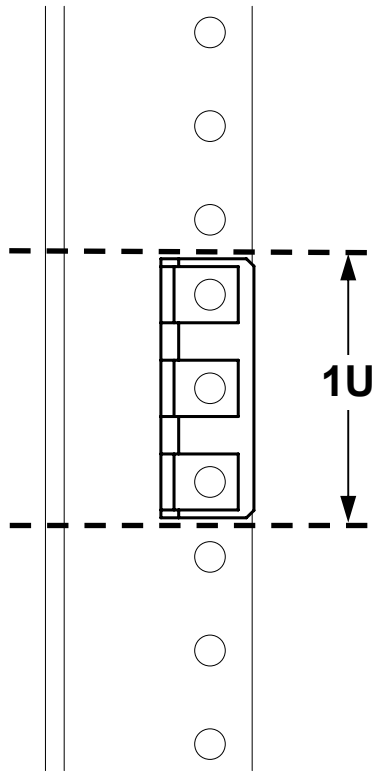

Bracket Installation Instructions (continued)

Step 5. Install the brackets determined by Step 3.

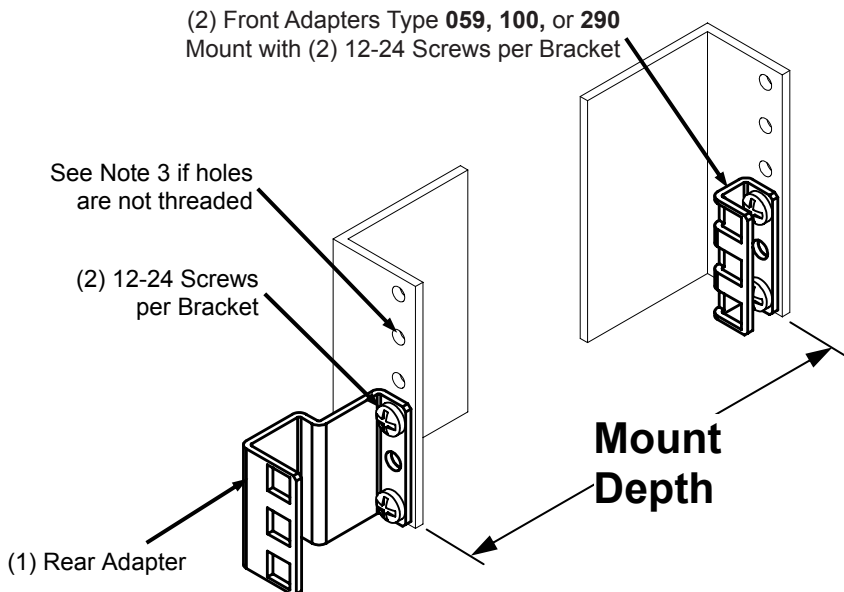

Refer to Slide Installation Instructions on Page 6

Assembly Notes:

1. Repeat installation shown for both sides of rack.
2. Double rear spacers are required for Mounting-Depths of 22 5/8" to 25 3/8". Refer to Appendix B.
3. Screws shown are for racks with threaded holes. If your rack has non-threaded holes, install the screw from the front of the rack, and use a nut on the inside against the adapter bracket.
4. If installation difficulties arise, see the alternate attachment method shown in Appendix C.

Slide Installation Instructions

Installing the Dell Slides and Cable Management Arm per Dell instructions. Installation photos can be viewed at www.racksolutions.com.

Appendix A - Double 2Post Front-Adapters

This step is only necessary for Double 2Post racks from 28 1/4" to 30"

Install the adapter on the back (rear) side of the front C-Channel post as shown below. Attach using (2) 12-24 screws. Repeat for both front brackets.

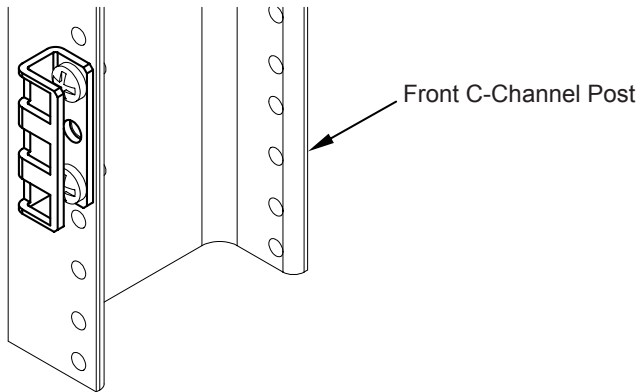

Appendix B - Dual Rear-Adapters

This step is only necessary for Mounting Depths from 22 5/8" to 25 3/8"

Attach the two brackets (indicated in step 2) together as shown below using (2) Cage Nuts and (2) 12-24 screws. Be sure the longer bracket is at the rear. Install the bracket pairs to the Rear Rack Rail as shown below using (2) 12-24 screws. Repeat for the opposite side.

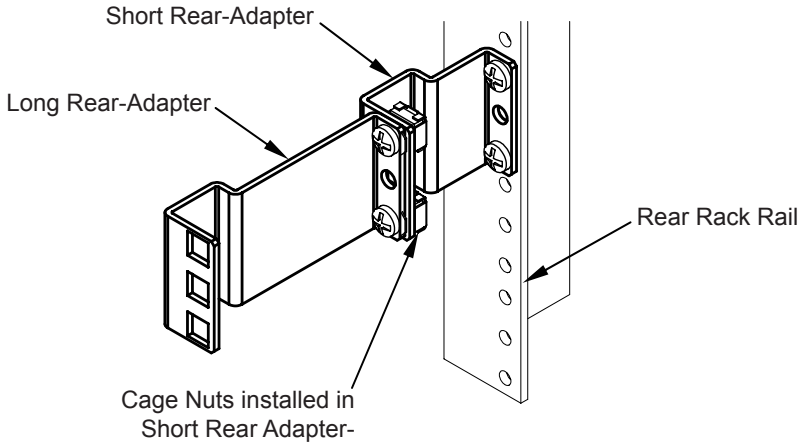

Appendix C - Alternate Front-Adapter Installation

Due to the variety of 19" rack designs, the standard installation may not work.

The figure below shows installation of the front spacer with the "U-Shape" pointing outward. Install using (2) 12-24 screws. Repeat for the opposite side.

If rack holes are not threaded, install screws through the rack, then through the adapter, and into a nut (supplied).

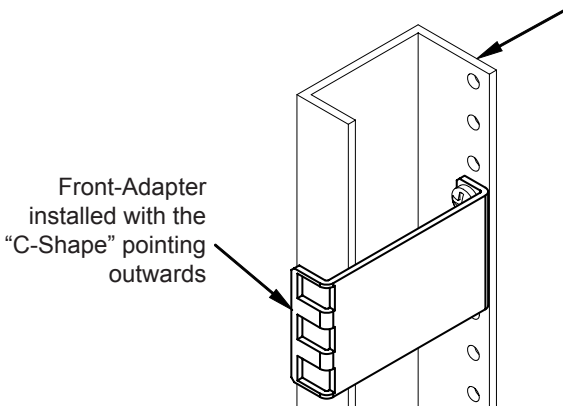



Boldly Creative



Expert Customer Service



Focus On Quality



Ships Same Day

Warranty Statement

Innovation First, Inc. warrants our products against defects in material and workmanship for a period of one (1) year from the date of purchase. Innovation First, Inc. liability shall be limited to repairing or replacing, at our option, any defective product.