



*Boldly Creative*



*Expert Customer Service*



*Focus On Quality*



*Ships Same Day*

## Dell 1U Dry Slide Rails - 4 Post and 2 Post Installation

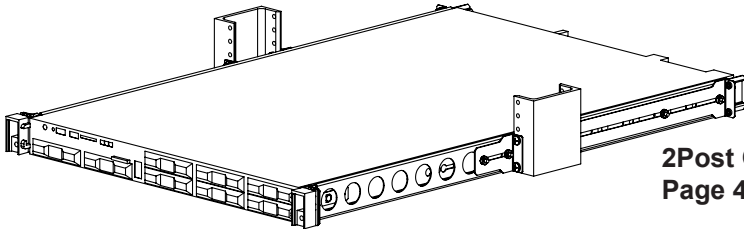
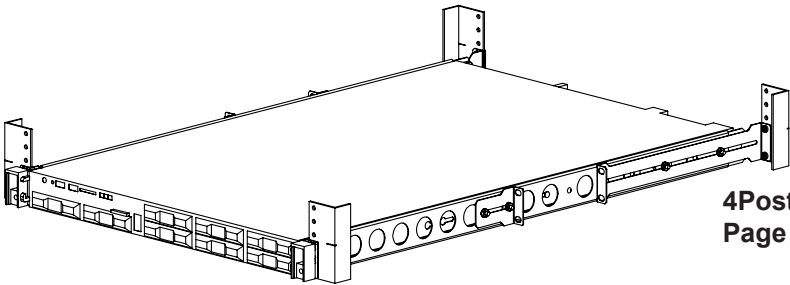

### Installation Instructions

Kit P/N:122-2579, 122-7390, 122-7650

# Kit Contents

---

## Kit Contents:

- (2) Outer Rail (Left & Right)
- (2) Inner Rail (Left & Right)
- (2) Rear Bracket

## Rear Bracket Hardware:

- (4) 8-32 x .375 Flat Head Screw
- (4) 8-32 Keps Nut

## Mounting Hardware:

- (8) 8-32 x .500 Pan Head Screw
- (2) Retainer Plate (Left & Right)
- (2) Mounting Plate

## Rack Mount 8x:

- (8) 10-32 x .500 Pan Head Screw
- (8) 12-24 x .500 Pan Head Screw
- (8) 12-24 x Square Nut
- (8) 12-24 x Cage Nut

# 4Post Installation Instructions

---

**Step 1. Rail Attachment:** Attach the Inner Rail to the chassis by aligning the Shoulder Lugs with the keyholes in the Inner Rail and slide until the retaining clip has secured the Inner Rail to the server. Repeat for the other side.

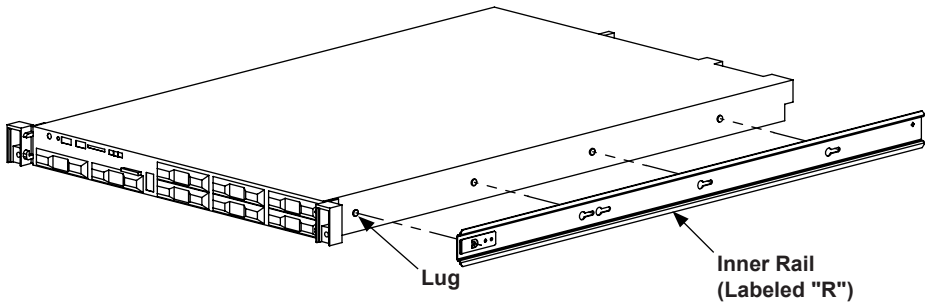

**Step 2. Attach Rear Brackets:** Attach the Rear Brackets to the Outer Rail Assemblies, using included 8-32 flat head screws and keps nuts. Ensure they are set to the required "Mounting Depth".

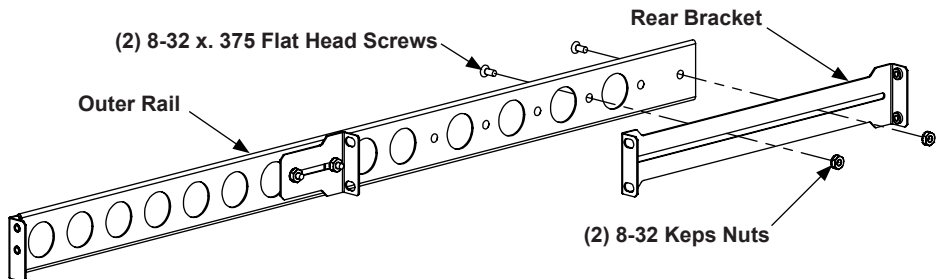

# 4Post Installation Instructions

**Step 3. Attach the rails to the rack:** Attach the Front and Rear of the rails to the 4Post rack as shown below using supplied 8-32 Pan Head Screws on each side. Repeat for the other side. Right side shown, Left side parts are labeled "L". Tighten the front and rear Pan Head Screws on the right side rail. Leave the front and rear Pan Head Screws on the left side rail slightly loose.

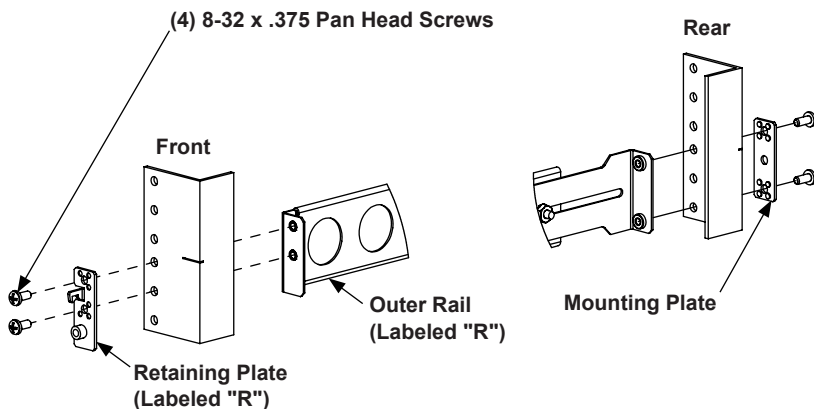

**Step 4. Install the equipment:** Slide the equipment all the way in. Tighten the (2) Pan Head Screws on the back of the left slide rail. Slide the equipment out about 8 inches and tighten the (2) Pan Head Screws on the front of the left slide rail.

**Note:** When tightening the loose rails, support the bottom of the server to ensure proper rail adjustment.

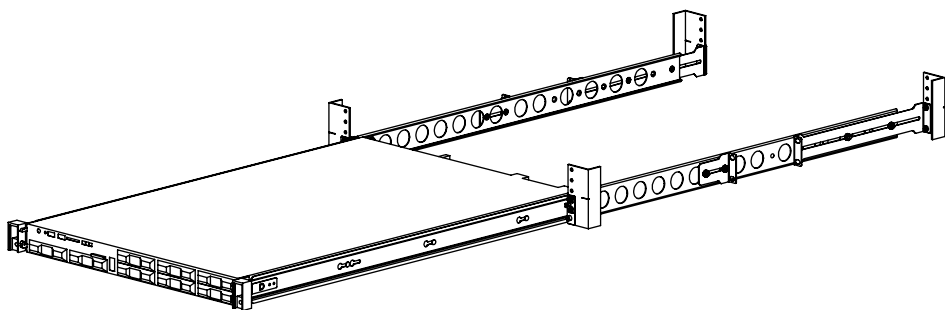

## 2Post Center Installation Instructions

- Step 1. **Rail Attachment:** Attach the Inner Rail to the chassis by aligning the Shoulder Lugs with the keyholes in the Inner Rail and slide until the retaining clip has secured the Inner Rail to the server. Repeat for the other side.

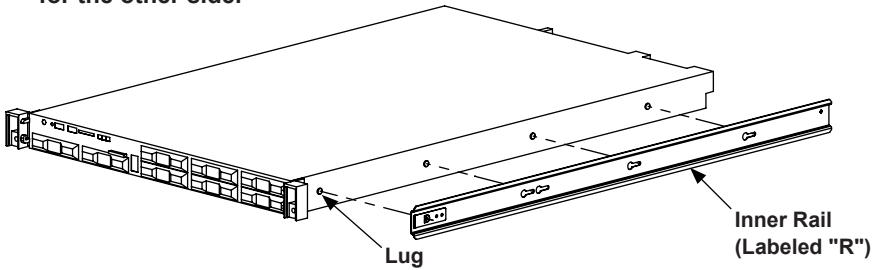

- Step 2. **Attach Rear Brackets:** Attach the Rear Brackets to the Outer Rail Assemblies, using included 8-32 flat head screws and keps nuts. Ensure they are set to the required "Mounting Depth".

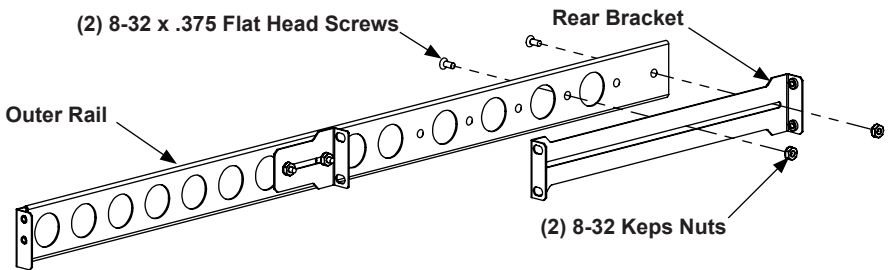

- Step 3. **Attach the rails to the rack:** Attach the Front and Rear of the rails to the 2Post rack as shown below using supplied 12-24 Pan Head Screws on each side. Repeat for the other side. Right side shown, Left side parts are labeled "L". Tighten the front and rear Pan Head Screws on the right side rail. Leave the front and rear Pan Head Screws on the left side rail slightly loose.

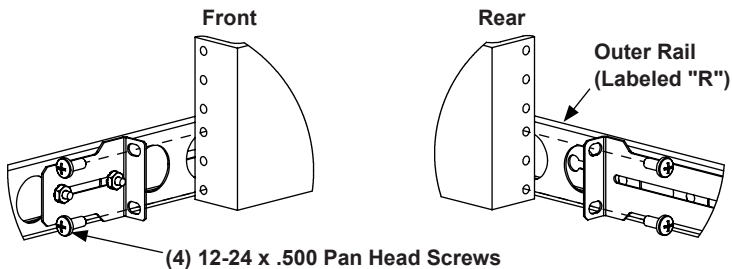

## 2Post Center Installation Instructions

**Step 4. Attach Retainer Bracket:** Attach Retainer Bracket to the front of the outer rail as shown below using the supplied 8-32 Pan Head Screws. Repeat for the other side.

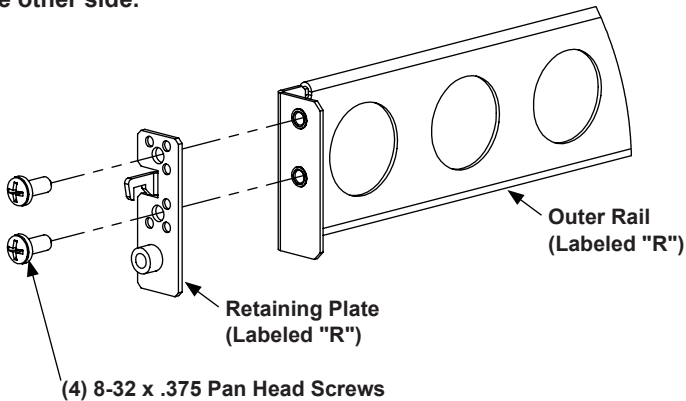

**Step 5. Install the equipment:** Slide the equipment all the way in. Tighten the (2) Pan Head Screws on the back of the left slide rail. Slide the equipment out about 8 inches and tighten the (2) Pan Head Screws on the front of the left slide rail.

**Note:** When tightening the loose rails, support the bottom of the server to ensure proper rail adjustment.

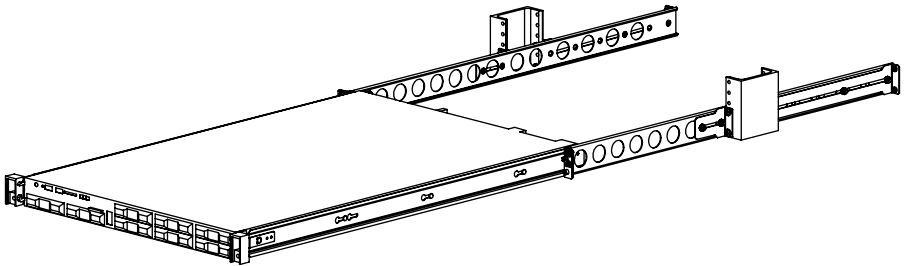







*Boldly Creative*



*Expert Customer Service*



*Focus On Quality*



*Ships Same Day*

#### Warranty Statement

Innovation First, Inc. warrants our products against defects in material and workmanship for a period of one (1) year from the date of purchase. Innovation First, Inc. liability shall be limited to repairing or replacing, at our option, any defective product.