

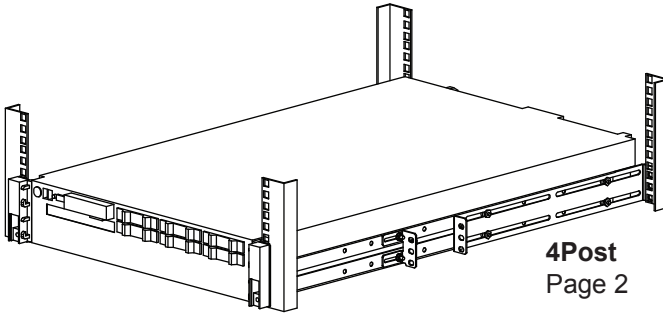

4Post and 2Post Rails for Dell PowerEdge R810

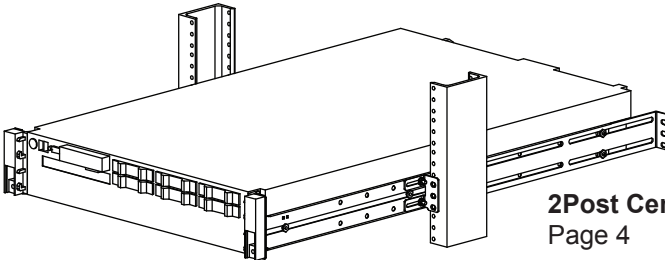

4Post
Page 2



2Post Center
Page 4

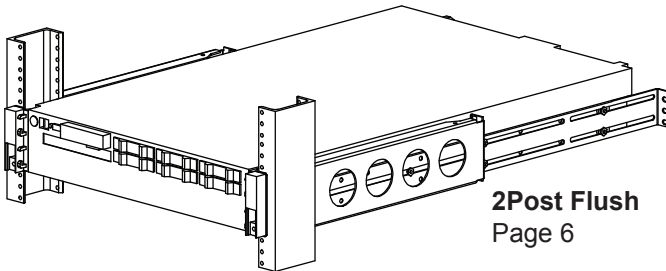

2Post Flush
Page 6

Installation Instructions

Kit P/N: 109-1737
109-1841

Kit Contents

Kit Contents:

- (1) Right Rail Assembly
- (1) Left Rail Assembly

Mounting Hardware:

- (12) 10-32 x 500 Pan Head Screws
- (12) 12-24 x 500 Pan Head Screws
- (12) 12-24 Cage Nuts

2Post Flush Adapter

(in 109-1841 only)

- (2) 2-Post Flush Adapter Brackets
- (8) 12-24 x 500 Slotted Self-Tapping Screws

4Post Installation Instructions

Step 1. Install cage nuts as shown at the front and rear of the rack: (12) 12-24 black cage nuts.

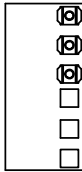

Front of Rack
(6) 12-24 black cage nuts

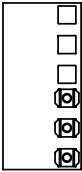

Rear of Rack
(6) 12-24 black cage nuts

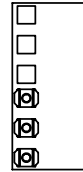

Step 2. The rail kit is pre-set for rack depths of 26.5" to 30.4" [673mm to 772mm]: If your rack is less than 26.5" [673mm] deep, move the hardware attaching the Rear Slider brackets to get the needed adjustment range. Moving the hardware attaching the Rear Slider can achieve any depth from 16" to 36" [406mm to 914mm]. The Angle Bracket may need to be removed.

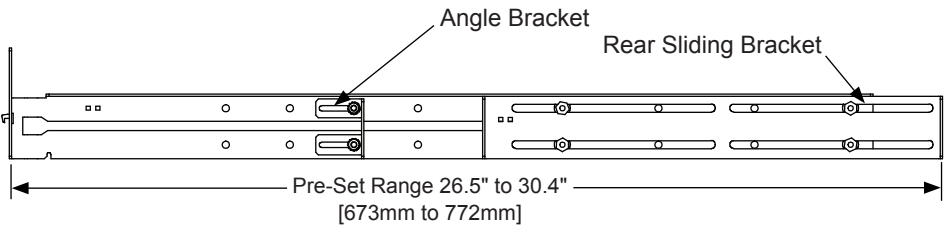

4Post Installation Instructions

Step 3. Attach the front and rear of both rails to the rack using supplied screws at each rail end. Tighten the front and rear screws on the right side rail. Leave the front and rear screws on the left side rail slightly loose.

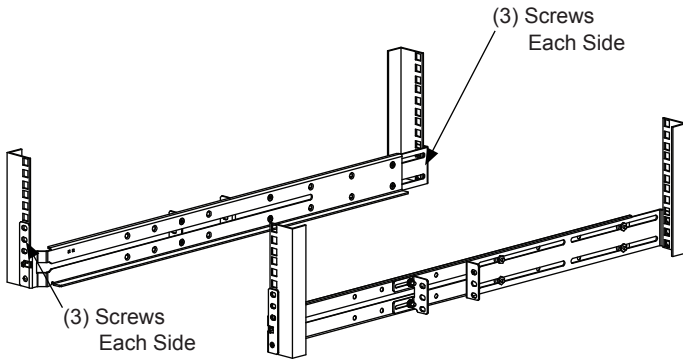

Step 4. Install the equipment using two people: With one person on each side of the equipment, slide the equipment onto the rails so the Equipment Mounting Nuts on each side slide into the Rail Slot on both sides. Slide the equipment all the way in. Tighten the (3) screws on the back of the left side rail. Slide the equipment out about 8 inches and tighten the (3) screws on the front of the left side rail.

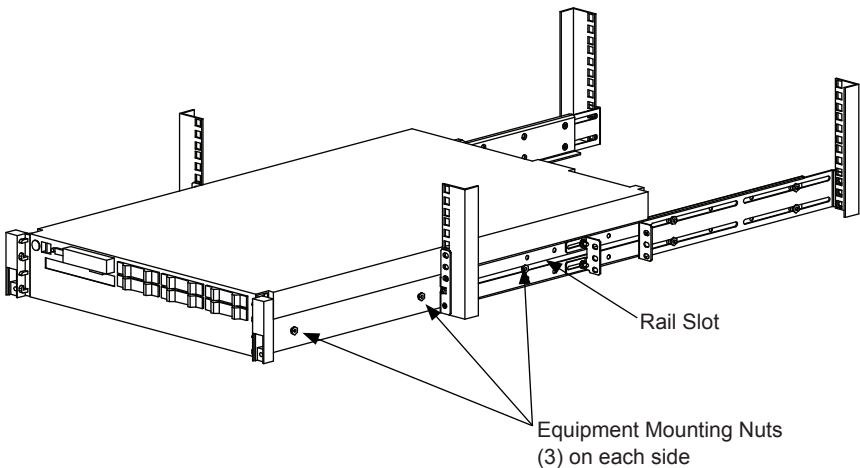

2Post Center Installation Instructions

Step 1. Installing rail kit: Installing this rail kit in a 2Post center rack requires a change to the pre-assembled rail configuration as follows (Note: this requires a 3/8" wrench or ratchet).

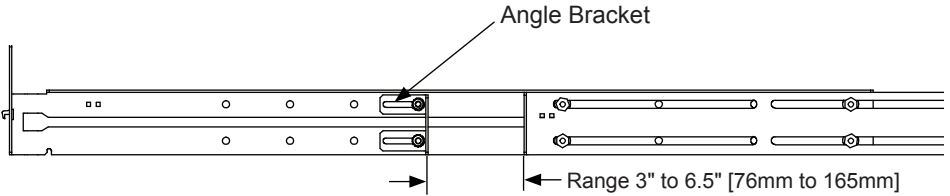

Step 2. Attach the rails to the rack:

- Attach the Front and Rear of the rails to the 2Post rack using (3) Supplied Pan Head Screws on each side.
- Tighten the front and rear screws on the right side rail. Leave the front and rear screws on the left side rail slightly loose.

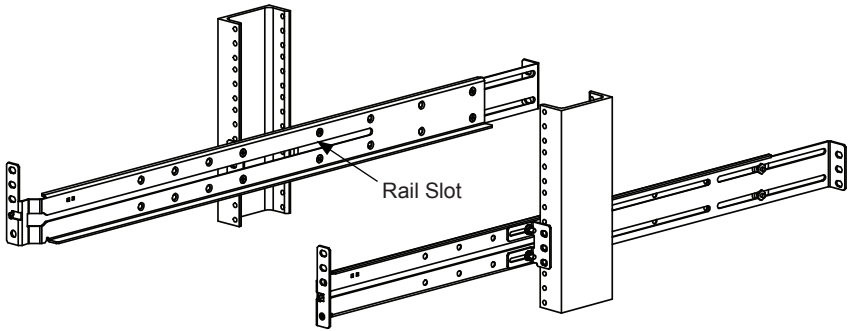

2Post Center Installation Instructions

Step 3. Install the equipment using two people: With one person on each side of the equipment, slide the equipment onto the rails so the Equipment Mounting Nuts on each side slide into the Rail Slot on both sides. Slide the equipment all the way in. Tighten the (3) screws on the back of the left side rail. Slide the equipment out about 8 inches and tighten the (3) screws on the front of the left side rail.

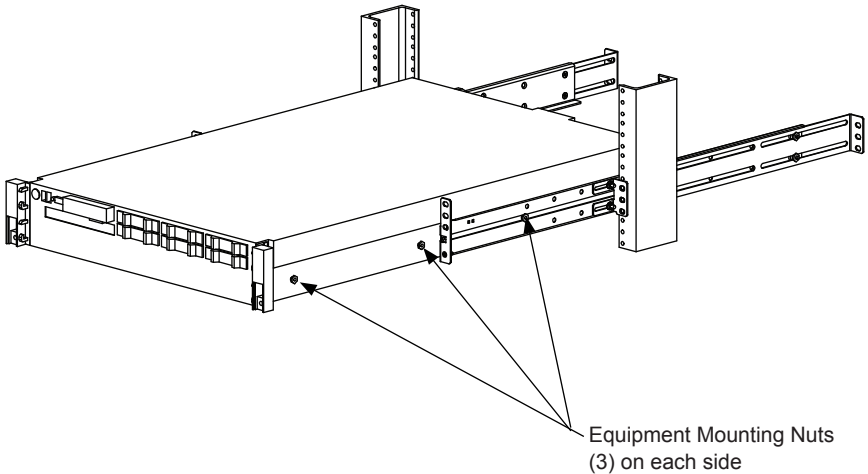

2Post Flush Front Installation Instructions

Step 1. Install Rails: Installing this rail kit in a 2Post flush rack requires the 109-1841 Kit and a change to the pre-assembled rail configuration as follows (Note: this will require a 3/8" wrench or ratchet).

Remove the Angle Brackets and associated hardware from the pre-assembled rails.

Rail in Supplied Configuration

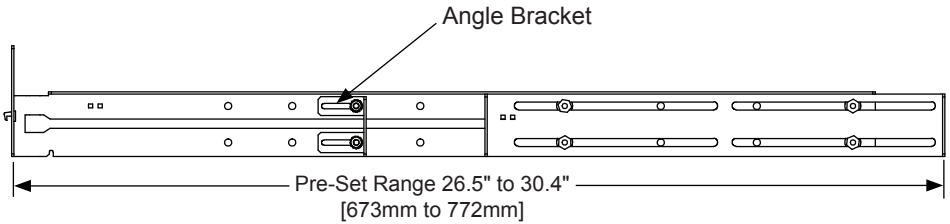

"Right" Rail in the new 2Post Flush Configuration

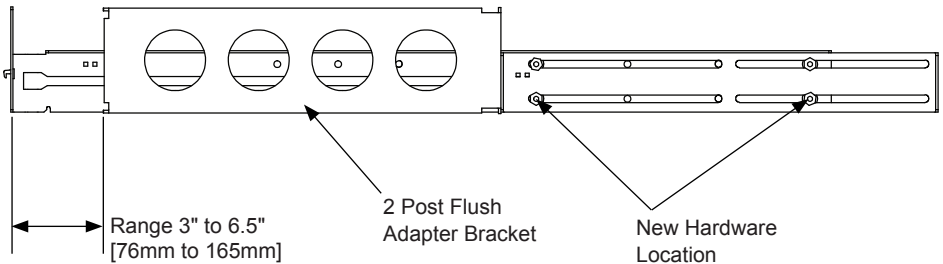

2Post Flush Front Installation Instructions

Step 2. Attach the rails to the rack:

- Attach the Front of the rails to the 2Post rack using (3) supplied Pan Head Screws on each side.
- Attach the 2Post Adapter Bracket per the "2 Post Racking System" Instructions.
- Attach the Rear of the rails to the adapter bracket using (3) 12-24 Pan Head Screws and (3) 12-24 Cage Nuts on each side.

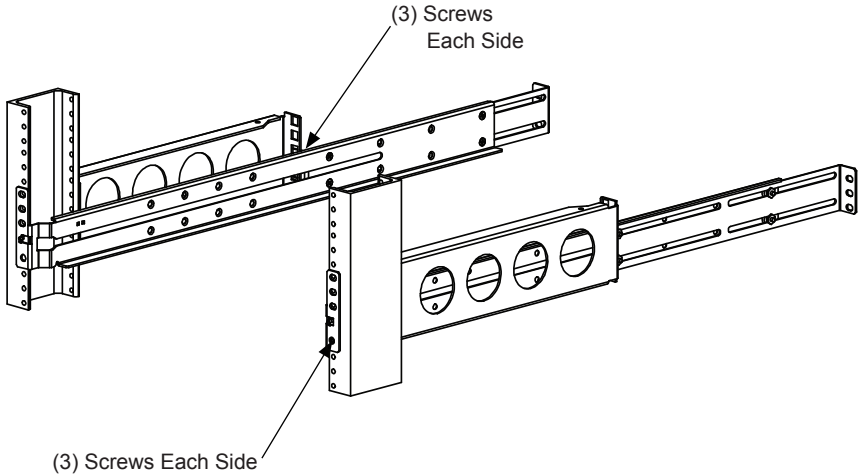



2Post Flush Front Installation Instructions

Step 3. Tighten the front and rear screws on the right side rail: Leave the front and rear screws on the left side rail slightly loose.

Step 4. Install the equipment using two people: With one person on each side of the equipment, slide the equipment onto the rails so the Equipment Mounting Nuts on each side slide into the Rail Slot on both sides. Slide the equipment all the way in. Tighten the (3) screws on the back of the left side rail. Slide the equipment out about 8 inches and tighten the (3) screws on the front of the left side rail.

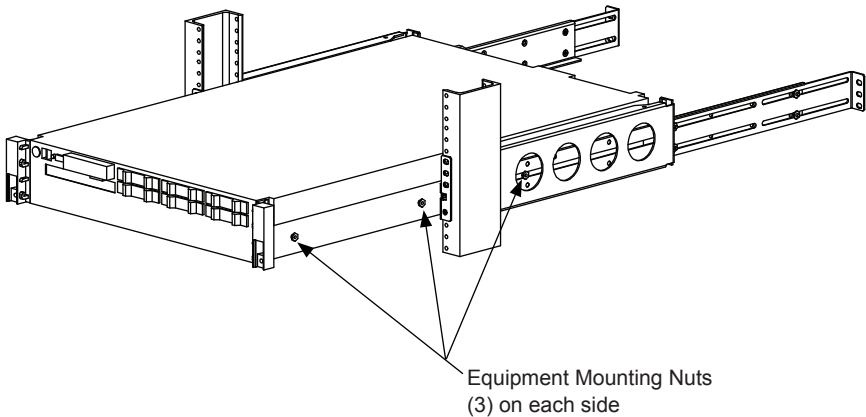

Warranty Statement

Innovation First, Inc. warrants our products against defects in material and workmanship for a period of one (1) year from the date of purchase. Innovation First, Inc. liability shall be limited to repairing or replacing, at our option, any defective product.

1737 1841